

Premium Booth 6mW x 3mD Right Corner Booth

LT-A-18-R Cnr
6mW x 3mD x 3.5mH

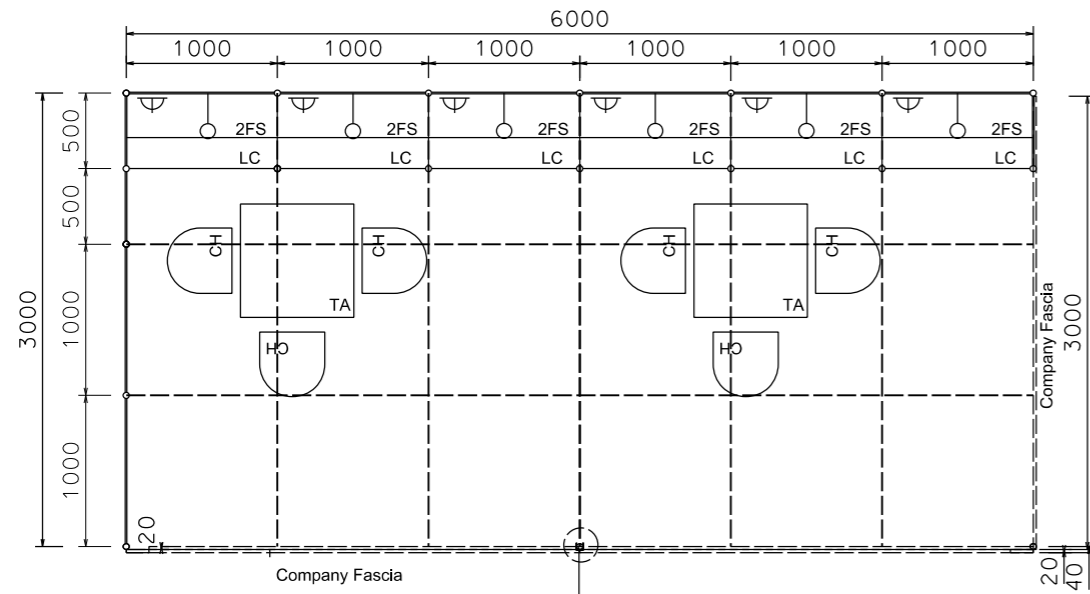

PLAN

SECTION A

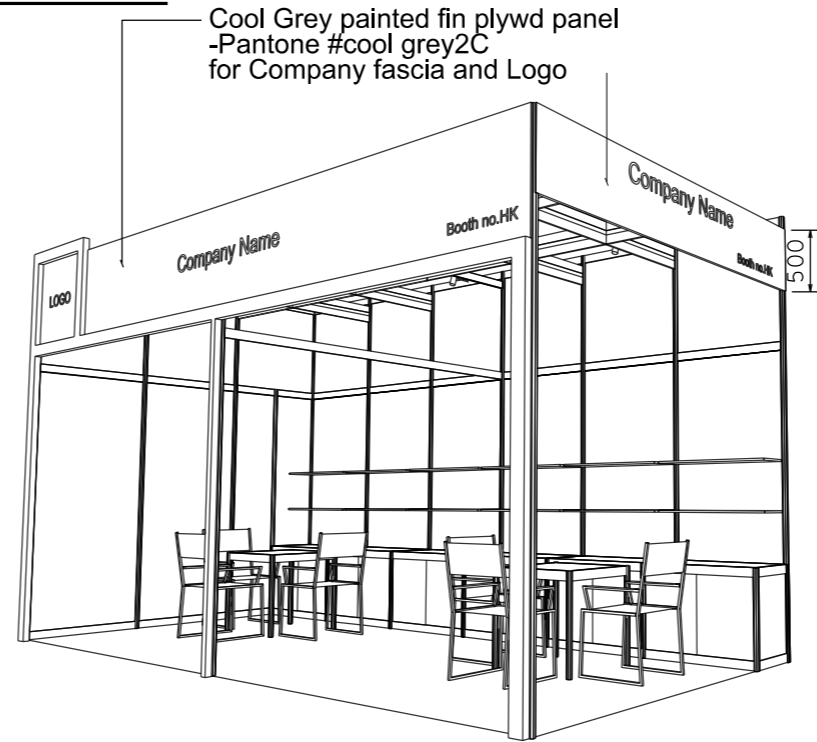

PERSPECTIVE N.T.S

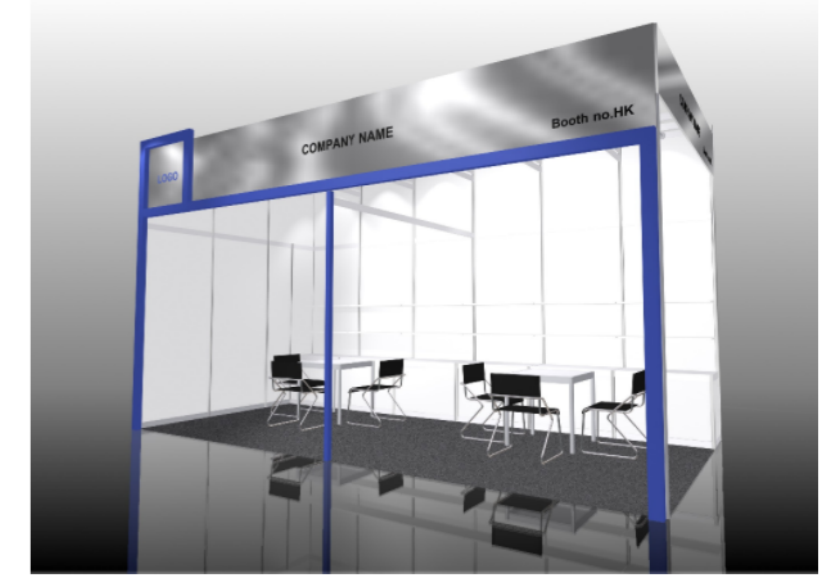

COLOUR PERSPECTIVE N.T.S

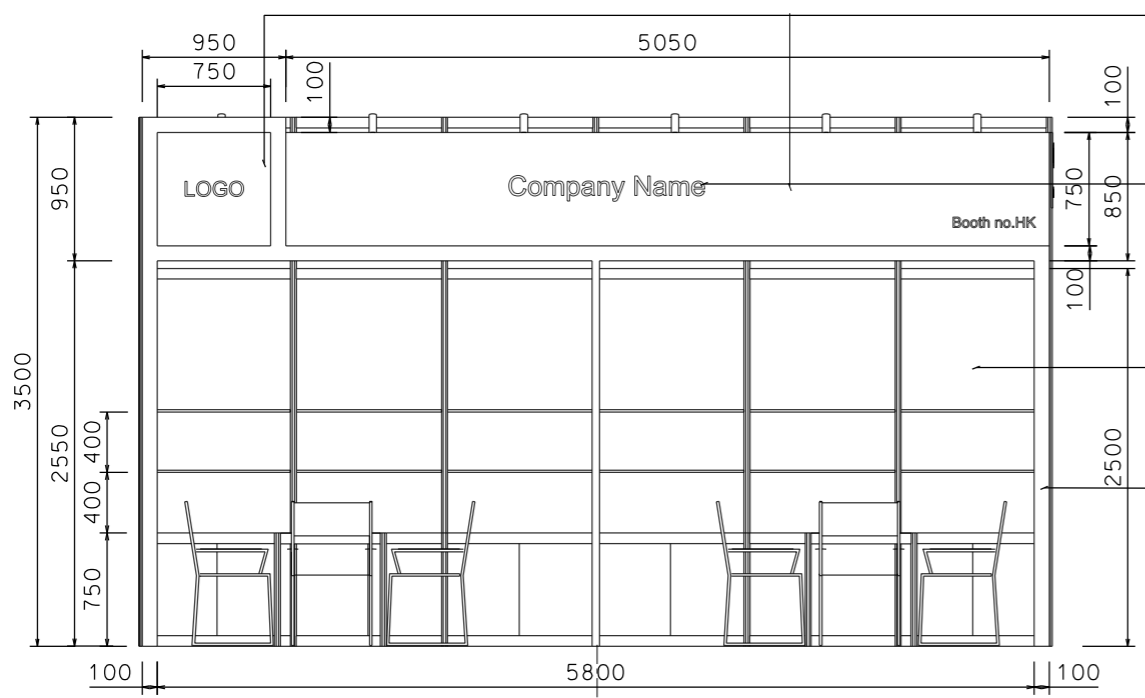

FRONT ELEVATION

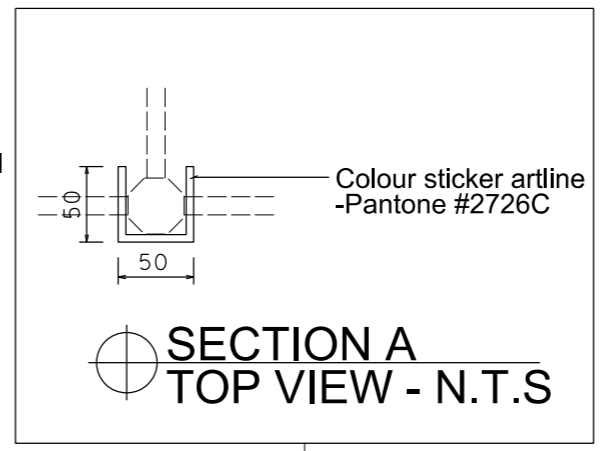

SECTION A TOP VIEW - N.T.S

BOOTH SPECIFICATION		QTY
	Lockable cabinet (1mL x 0.5mD x 0.75mH)	6
	Wooden shelf (flat) (1mL x 0.3mD)	12
	Square meeting table (0.7m X0.7m x 0.75mH)	2
	Black leather chair	6
	Longarmed spotlight w/23 watt energy saving lamp (yellow) set at 3.5mH	6
	800w Square pin power socket	6
	Ceiling grid (175mmH) set at 3.4mH	27m

FILE PATH - L:\Local Fair Premium Booth 2011\LT-A layout\LT-A-2dLayout_2012.dgn



NOTES UNLESS OTHERWISE SPECIFIED ALL DIMENSIONS ARE IN MM.

.....

.....

.....

REVISION
19/10/09
23/02/2010
25/02/2010
13/12/2011

DATE:	12-01-2009
SCALE:	1 : 50 (A3)
DRAWN BY:	..
CHECKED BY:

TITLE

Premium Booth
LT-A-18
R-Corner

PROJECT

PREMIUM BOOTH
6m x 3m

DATE: XXXXXXXX

SHEET

LT-A02a