

Premium Booth 6mW x 3mD One side open

LT-C-18
6mW x 3mD x 3.5mH

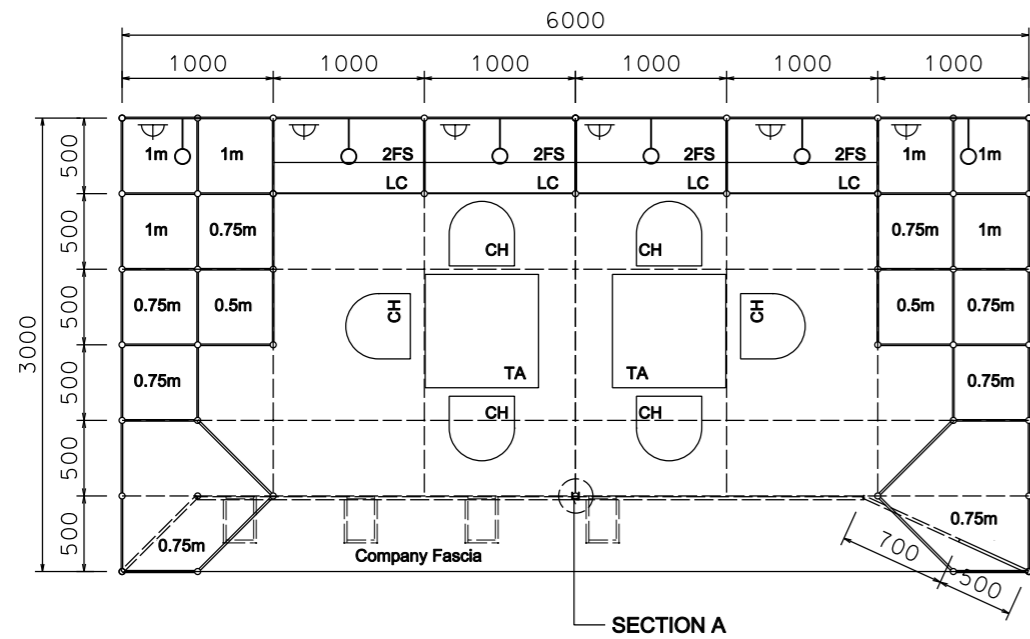

PLAN

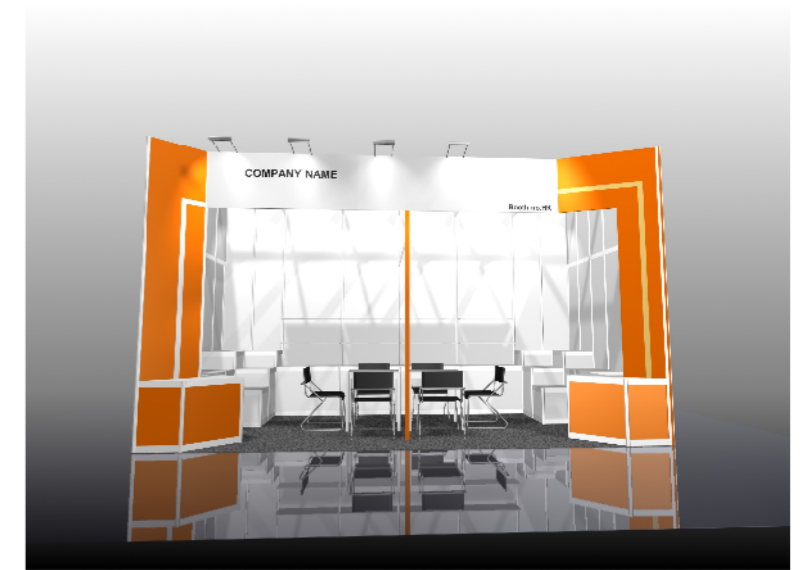
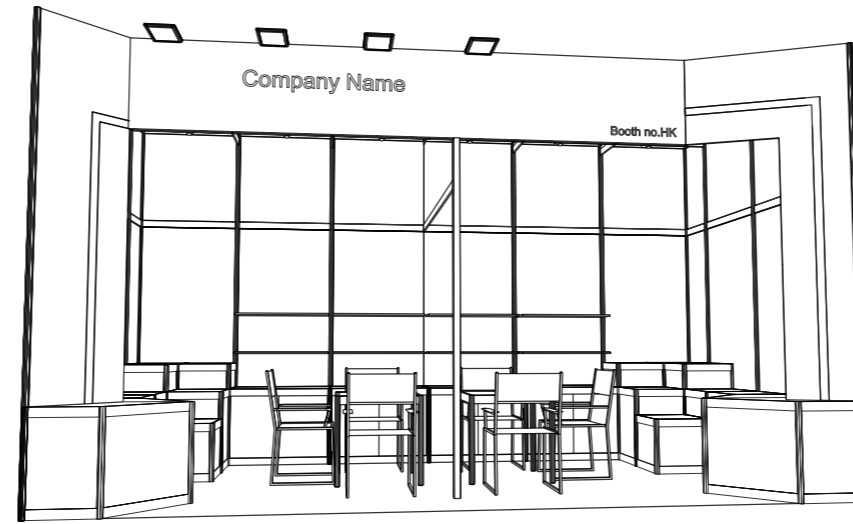

COLOUR PERSPECTIVE N.T.S

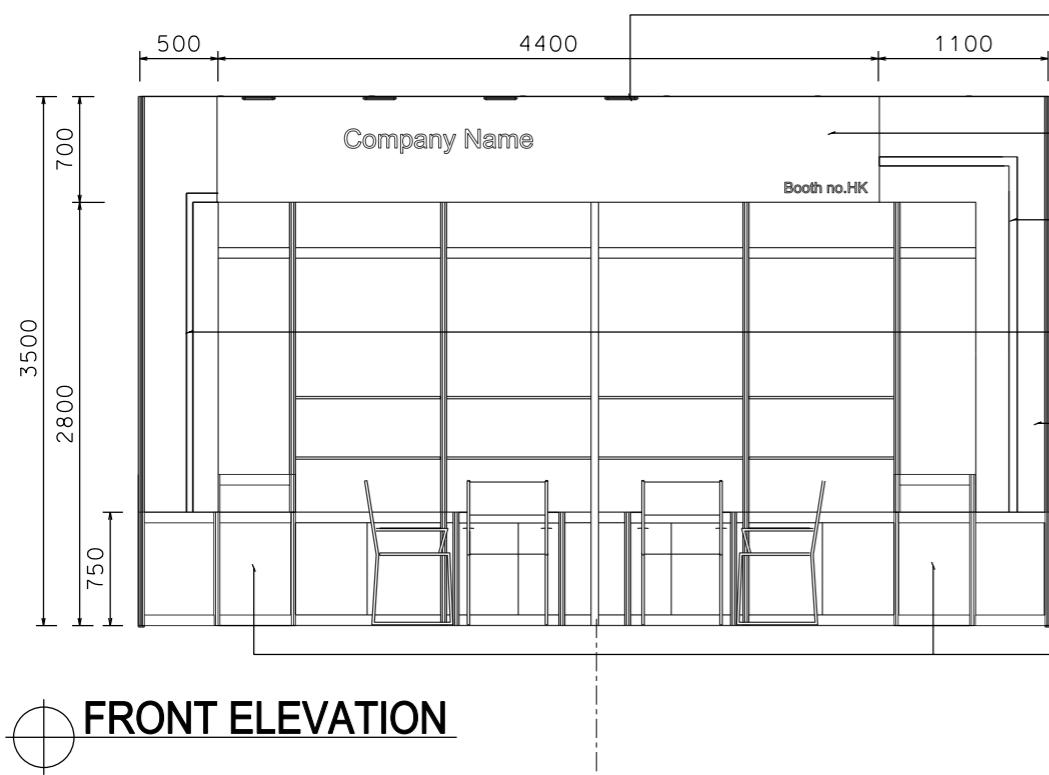

FRONT ELEVATION

PERSPECTIVE N.T.S

Gilbert lamp (for Fascia)

Wooden Company Fascia
4400mmW x 700mmH

60mmW Colour sticker artline
-Pantone #134C
(Respect M-3146)

60mmW white color
sticker artline

Plywd panel in colour
sticker lamination
-Pantone #151C
(Respect M-3178)

Plywd panel in colour
sticker lamination
-Pantone #151C
(Respect M-3178)

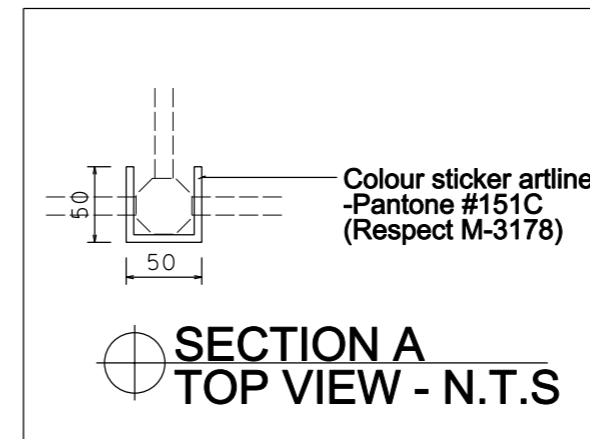

BOOTH SPECIFICATION		QTY
	Lockable cabinet (1mL x 0.5mD x 0.75mH)	4
	Wooden shelf (flat) (1mL x 0.3mD)	8
	1mH podium (0.5m x 0.5m x 1mH)	6
	0.75mH podium (0.5m x 0.5m x 0.75mH)	6
	0.5mH podium (0.5m x 0.5m x 0.5mH)	2
	0.75mH podium in colour sticker lamination-Pantone#151C (Respect M-3178)	2
	Square meeting table (0.7m X 0.7m x 0.75mH)	2
	Black leather chair	6
	Longarmed spotlight w/23 watt energy saving lamp (yellow) set at 3.5mH	6
	800w Square pin power socket	6
	150W Gilbert lamp (for fascia)	4
	Ceiling grid (175mmH) set at 3.5mH	30.5m

FILE PATH - L:\Local Fair Premium Booth 2011\LT-C layout\LT-C-2d\layout_update.dgn



NOTES UNLESS OTHERWISE SPEBIFIED ALL DIMENSIONS ARE IN MM.

.....
.....
.....

REVISION
20/10/09

DATE: 12-01-2009
SBALE: 1 : 50 (A3)
DRAWN BY: ..
BHEBKED BY:

TITLE
Premium
Booth
LT-C-18

PROJEBT
PREMIUM BOOTH
6m x 3m
DATE: XXXXXXXX

SHEET
LT-C02